

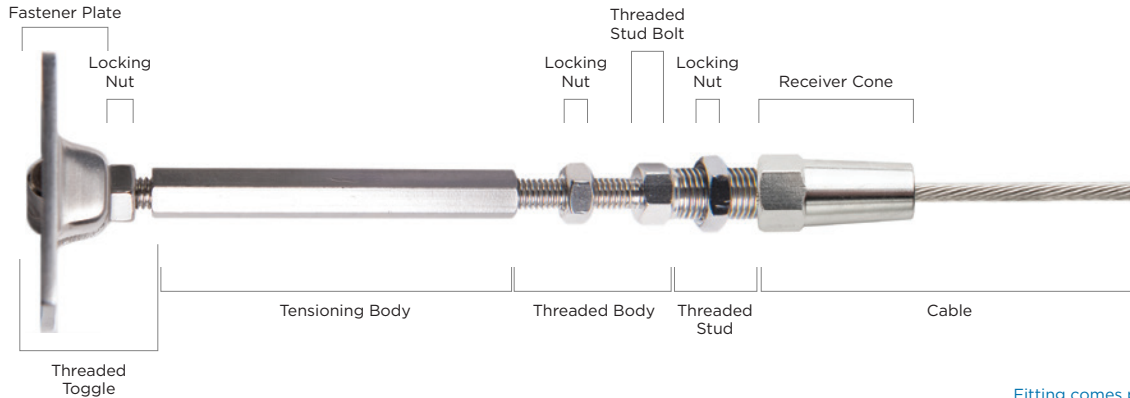

Installation Instructions for Wood Posts Stair Runs, Tensioning

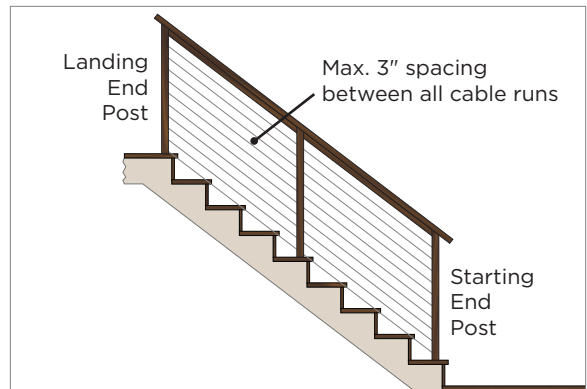

Fitting comes preassembled.
Supplied with two #8 x 1-3/4" stainless steel alloy 316 screws for wood posts.
Fasteners for metal posts are not supplied.

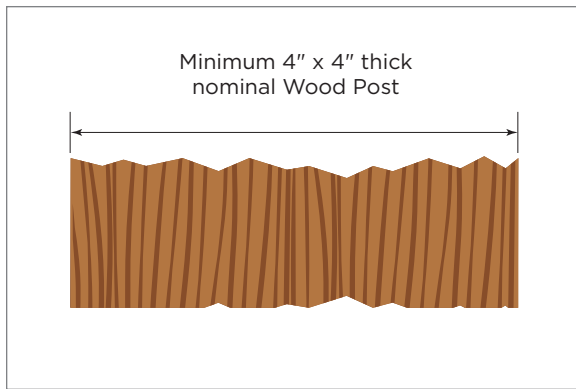

A. Post Preparation

A1. Ensure that framework for End Posts and Intermediate Posts have been mounted to the stair or staircase.

A2. Begin at the lowest cable run of the Starting End Post and run a chalk line to the top of the Landing End Post. Snap and mark the chalk line parallel the slope angle of the stairs. Measure 3" on center perpendicular to the line snapped and sequentially snap and mark a chalk line for the cable runs above.



ATTENTION INSTALLERS! DO NOT REMOVE CONE

This new and improved Jaw does not require the cone to be removed. Removing the cone will render the Jaw to be **UNUSABLE**. In case of accidental removal, a replacement Jaw (CR1921) can be ordered at geobezdan.com/cr1921

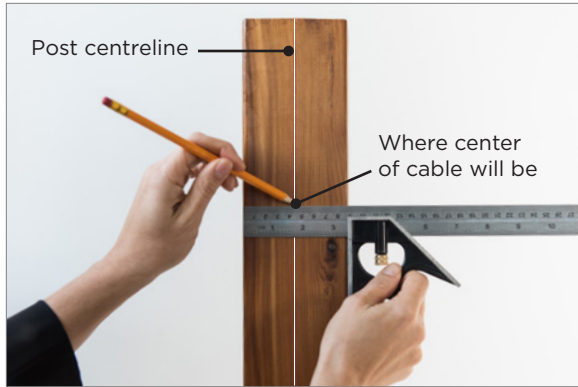

A3. Using a carpenter's square, measure and draw a line to the inside of the post face to find the center of your cable. Use the fitting as a guide to determine to centerline.

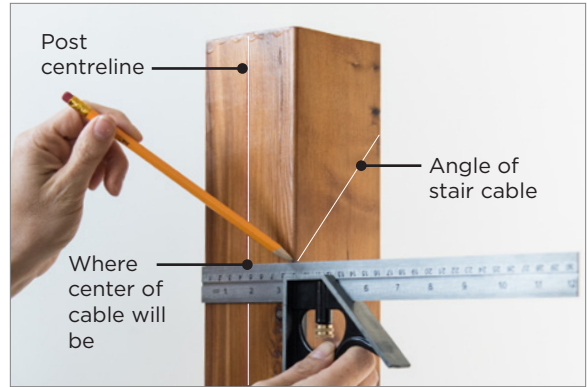

A6. **Intermediate Post:** Determine the marked angle on the post. An angled jig (not shown) can aid in drilling on an angle to minimize errors. Drill at the marked angle through the intermediate posts to accept 1/8" cable with a 5/32" drill bit. Ensure that the drill holes are in line and at the same angle as subsequent intermediate posts before drilling. Remember to measure twice, drill once.

NOTE: The maximum hole spacing must be 3" apart to meet Building Code requirements

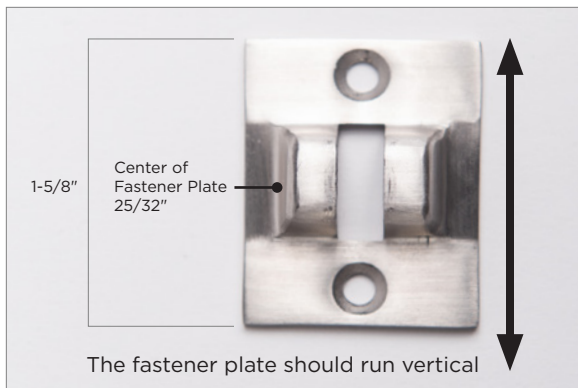

A4. The center of each Fastener Plate must be spaced 3" on center. Draw a line across the face of the Fastener Plate to determine the horizontal centerline. Mark the holes on the centerline of the end post for drilling beginning from the top of the end post.

A5. **End Post:** Drill a pilot hole using a 1/8" drill bit for wood. Drill 1/2" deep, **DO NOT** drill through the end post.

IMPORTANT INSTALLATION NOTE

LEVEL RUNS LESS THAN 25'

Prior to installing the Tensioner, ensure that the cable is secured within the non-tensioner on the opposing end post.

- ▶ For metal and wood posts, refer to CR1635 and CR1735 (non tensioner surface mount).

LEVEL RUNS MORE THAN 25' AND LESS THAN 45'

The tensioning fitting must be affixed to each end post.

- ▶ For metal and wood posts, refer to this instruction set for both end posts.

B. Fastening the Tensioning Body to the Post

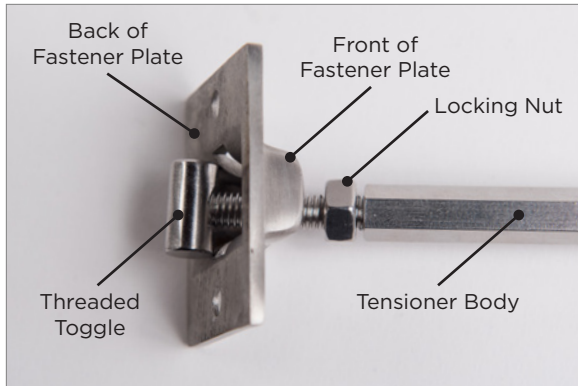

- B1. To allow for the Fastener Plate to be securely attached to the end post with screws ensure that the threaded toggle can swivel freely within the base. The Locking Nut may need to be backed away from the front of the Fastener Plate.



- B2. Affix the Fastener Plate to the post with the two #8 x 1-3/4" stainless steel alloy 316 screws for wood posts.

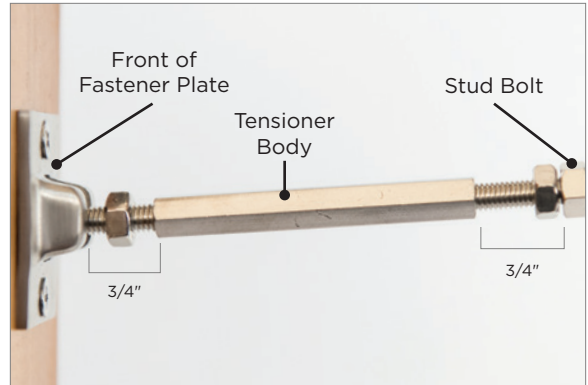

- B3. Ensure there is a 3/4" gap between the Fastener Plate and the Tensioner Body as well as a 3/4" gap between the Tensioner Body and the Stud Bolt. Adjust the Hex Shaft on the Threaded Toggle and Tensioning Screw until a 3/4" gap on each side of the Tensioning Body has been achieved.

C. Fastening the Locking Nut to the Threaded Stud

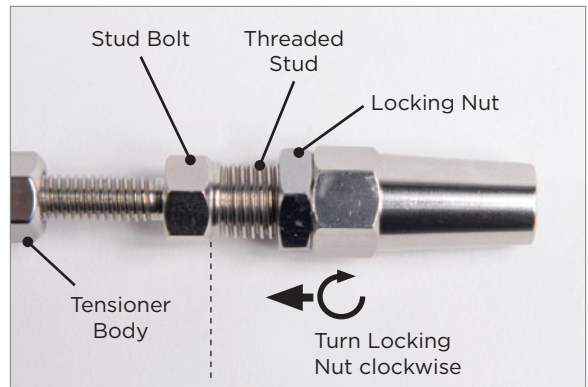

- C1. Screw the Locking Nut in a clockwise motion on to the Threaded Stud until the Locking Nut is flush against the Threaded Stud Bolt.

D. Fastening the Cable

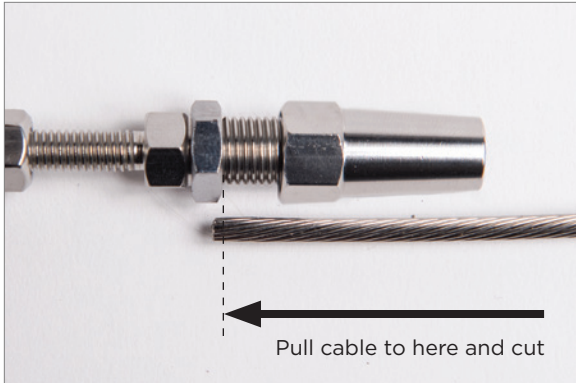

D1. Pull the cable, which is already attached to the non-tensioning fitting on the opposing end post, to the face of the Locking Nut. Measure, mark, and then cut the cable using a cable cutter.

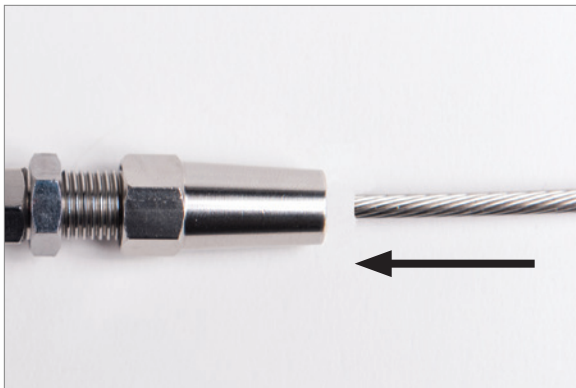

D2. Insert the cable into the cone.

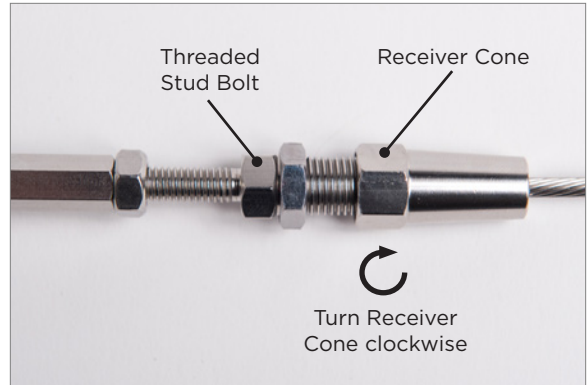

D3. Use a 10mm wrench to hold the Threaded Stud Bolt. Holding the Threaded Stud Bolt will keep it from spinning while the Receiver Cone is being tightened.

Tighten the Receiver Cone along the Threaded Stud. This step will crimp the Jaw and Receiver Cone onto the cable. Use a 12mm wrench to turn the Receiver Cone clockwise and securely fasten onto the Threaded Stud until the Receiver Cone can no longer turn.

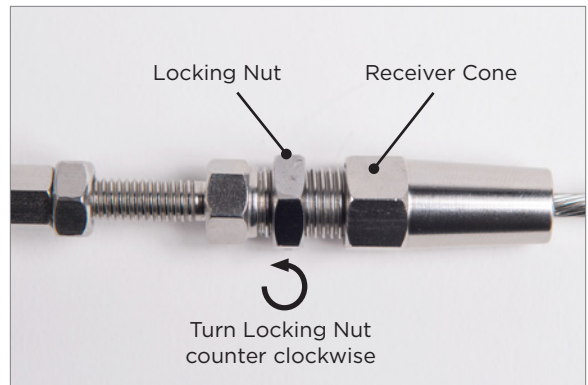

D4. Use a 12mm wrench to turn the Locking Nut in a counter clockwise direction, this will lock the Receiver Cone into place.



Use a 12mm wrench to hold the Receiver Cone while the Locking Nut is being tightened.

E. Tensioning

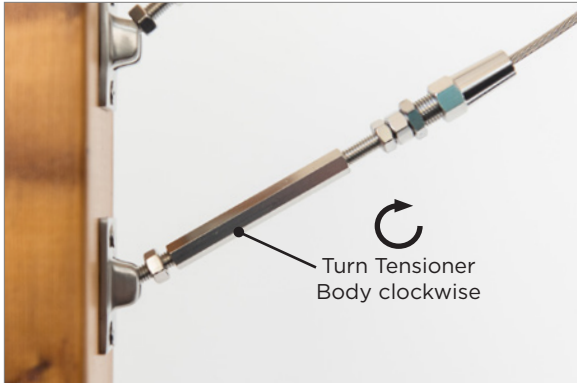

- E1. Use an 8mm wrench to tighten the Tensioner Body in a clockwise direction.

Follow the recommended tensioning sequence (below) to ensure proper installation.

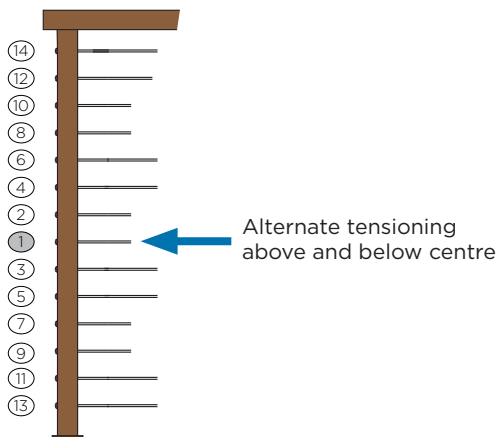

Alternating between cables above and below the center run of cable, tighten until the cable is taut.

As tension is applied the surrounding cables may become loose. If this happens move onto the next sequenced cable run.

Repeat the sequence if necessary, re-tensioning the cables starting from the center cable run.

It is important to keep the cable from spinning during tensioning. Do not over tension.



- E2. Once all tensioners have been tightened, test the cable run for deflection. Once all cable runs are properly tensioned the cable spacing should measure 3". The cable runs should be taut. The cable should not exceed a 1/2" deflection and a 4" sphere should not be able to pass between two cable runs. If more than 1/2" deflection exists, repeat step E1 until greater tension has been achieved. Do not over tension.

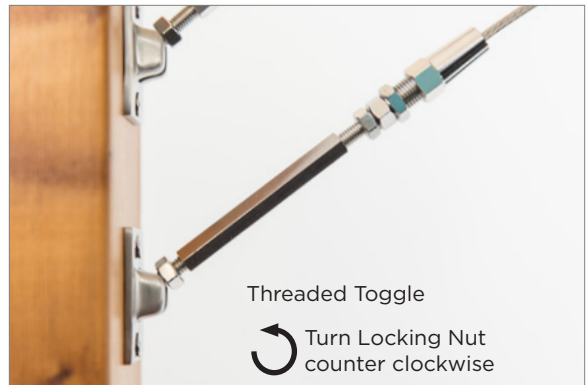

- E3. Finish by tightening the Locking Nut on the Threaded Toggle in a clockwise direction until it sits flush with the Tensioning Body or a counter clockwise direction until it sits flush with the fastening plate.

Limited Warranty

Bezdan warrants to the original property owner/purchaser that Bezdan stainless steel cable and fittings are free of defect for a period of ten (10) years from the date of receipt. This warranty covers defects in workmanship and materials under normal use, conditions, installation and maintenance in accordance with the product specifications and procedures described in the cable rail installation and maintenance instructions. Learn more at geobezdan.com/bezdan-cable.